

JET CHISEL

Powerful scaling with multi-needles



Never skip a blow, cleans and descales all jobs fast. Gets into extremely restricted areas...

An asset in any industry...de-slugging, de-sputtering welds, cleaning, castings, brick, stonework, and other materials. Jet Chisel is a prime pneumatic performer in each of these and other tough job areas.

Maximum performance in a light-weight, minimum-size air tool, Jet Chisel delivers years of trouble-free, efficient operation. And it's a tool that gets all the way down to the surface of matters.

Quick, Jet Chisel needles adjust to any surface contour automatically. They get deep into corners, all the way into uneven surfaces, all types of curvatures making it a tool no shop should be without. It's an equally efficient time-saver in ship-board applications, too.

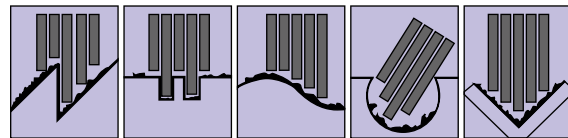

Shot Peening Effect

Reinforcement of the deteriorated part by shot peening effect. Increase the strength through imparting a residual stress to the surface of a workpiece by high speed tapping of the needle punch. Most suitable for a reinforcement of deteriorated parts in the welder.

Full Automatic System

The only unit of it's kind on the market without springs. This means no springs to break...no irregular power... and the advantage of low air consumption.

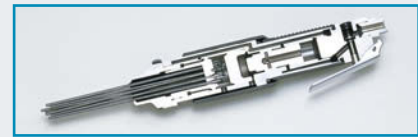

Model **AJC-16** Slim Type

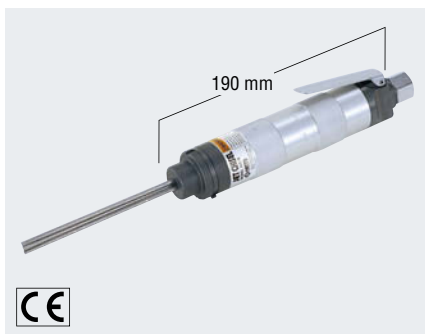

Model **JT-20** Popular Type

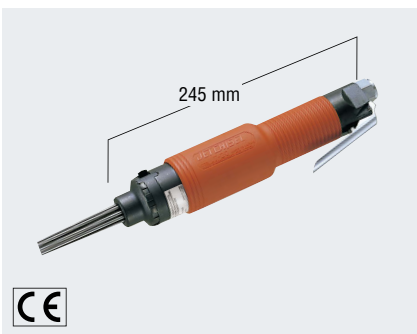

Model **JEX-20** Low Vibration Type

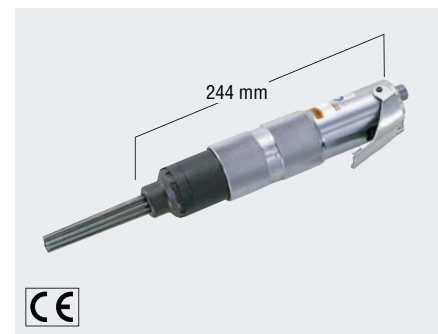

Specifications

Model	AJC-16	JT-20	JEX-20
Rated Air Pressure MPa {kgf/cm ² }	0.6 {6}	0.6 {6}	0.6 {6}
Air Consumption (No load) m ³ /min	0.07	0.2	0.2
Stroke Speed min ⁻¹	6,000	4,000	4,000
Needle qty	OD 2 × 7 pcs. or OD 3 × 3 pcs.	OD 2 × 29 pcs. or OD 3 × 12 pcs.	OD 2 × 29 pcs. or OD 3 × 12 pcs.
Hose Size inch	3/8	3/8	3/8
Mass (Weight) kg	0.98	2.4	2.75

Standard Accessories	AJC-16	JT-20	JEX-20
	<ul style="list-style-type: none"> • Needle OD 3 mm × 180 mm : 3 pcs. (Needle OD 3 mm × 180 mm : 3 pcs. on the body) • Bushing R 3/8 × NPT 3/8 : 1 pc. • Hose Nipple R 3/8 × 3/8 : 1 pc. 	<ul style="list-style-type: none"> • Needle OD 3 mm × 180 mm : 12 pcs. (Needle OD 3 mm × 180 mm : 12 pcs. on the body) • Bushing R 3/8 × NPT 3/8 : 1 pc. • Hose Nipple R 3/8 × 3/8 : 1 pc. 	<ul style="list-style-type: none"> • Needle OD 3 mm × 180 mm : 12 pcs. (Needle OD 3 mm × 180 mm : 12 pcs. on the body) • Bushing R 3/8 × NPT 3/8 : 1 pc. • Hose Nipple R 3/8 × 3/8 : 1 pc.